



CREATIVE LIFT® - CERAMIC LIFT MAGNET OPERATION MANUAL

Conforms ASME B30.20 standards Bth:1 Design Category B Service Class 3

INTRODUCTION

READ AND UNDERSTAND THIS MANUAL BEFORE INSTALLATION AND OPERATION OF YOUR Lift Magnet PRODUCT.

If used carelessly or improperly, there is a possibility that property damage or personal injury can result. The responsibility for safe operation ultimately rests with the operator.

Working load Limit (WLL):

Your Lift Magnet has a stated **Working Load Limit (WLL)** which is sometimes referred to as the Lift Capacity. The stated **Working Load Limit** value is calculated by applying a De-rating (Design) factor to the **maximum value** of the Lift Magnet. The **maximum value** is determined by pulling a new magnet in a perpendicular motion off of a thick, newly machined, piece of steel. This method of testing is conducted under what is considered "ideal conditions." The amount of force it takes to break the Lift Magnet away from the steel test surface under these conditions is the Lift Magnet's **maximum value**.

The stated **Working Load Limit** value is for the benefit and safety of the user. Ideal conditions rarely exist in the field. Conditions such as worn or damaged magnet poles and steel surfaces that have mill scale, oxidation, dirt, or other coatings will cause a

GENERAL INSTRUCTIONS

Installation and start-up are very simple and safe provided that the load limits and the application standards of the Lift Magnet are observed for handling suspended loads.

1. Remove the Lift Magnet from packaging and set on a non-ferrous floor or support structure. This operation is to be done with a crane or hoist of appropriate capacity by hooking to the lift lug the top of the Lift Magnet. Check the Lift Magnet for missing parts, loose bolts or damage. Tighten where necessary or contact the manufacturer.
2. Clean the area where the Lift Magnet will touch. Take care when handling Lift Magnet models that have an exterior mechanical release, such as a roller cam, as they are "Always On" and will engage the steel automatically when the Lift Magnet poles are in close proximity to steel. With a crane or hoist of appropriate capacity, position the Lift Magnet in the center of the load to be moved. Be careful to make sure that the load to be lifted does not exceed the Lift Magnet's **Working Load Limit** for the steel's thickness. See the **Safety Precautions** section for more information.
3. Make sure the magnetic poles are in full and perfect contact with the load and that the cam release device of the Lift Magnet, if applicable, is properly located on the load to be lifted. The

SAFETY MEASURES

- ALWAYS** use the entire pole surface of the Lift Magnet.
- ALWAYS** keep contact pole areas perfectly flat & parallel on the surface of the load.
- ALWAYS** keep contact pole areas and surface of the load clean and free of debris.
- ALWAYS** protect pole surfaces from oxidation after use by treating with some oil.
- ALWAYS** store magnet in a dry environment.
- ALWAYS** check the magnetic poles to make sure they are flat and not damaged.
- DO NOT** place any body part between the Lift Magnet's face and steel. Sudden magnetic attraction may occur causing bodily harm.
- DO NOT** hoist a load weighing more than the Lift Magnet's stated Working Load Limit or capacity.
- DO NOT** attempt to engage the Lift Magnet before resting it on the steel to be lifted. If you have an "Always On" Lift Magnet use, hold the release handle in the release position while lowering the Lift Magnet onto the load to prevent sudden attraction of the Lift Magnet and the steel material.
- DO NOT** hoist the load before locking the handle in the "ON" position (if applicable) or making sure the release handle is not interfering with the load or hoist/crane.
- DO NOT** hoist a load if it is flexing or unbalanced. Load must not be angled more

reduction in performance of the Lift Magnet.

De-rating (Design) Factors:

2:1 = 50% of **maximum value** - BasicLift™

3:1 = 33% of **maximum value** - Creative Lift®, DynamicLift™, PowerLift®, VersaLift™

Loss of Magnetism:

Under normal use conditions, a permanent magnet can experience a decrease in its original **Working Load Limit**. The most common factors which can cause a loss of strength include:

- » Everyday wear and tear on the Lift Magnet's face such as: fine metal buildup on or between the Lift Magnet's poles, nicks or gouges in the magnet's poles, rust buildup, etc.
- » Exposure to Extreme Temperatures
 - » BasicLift™ and Creative Lift® operating range is -76°F (-60°C) to 300°F (148°C).
 - » DynamicLift™, PowerLift® and VersaLift™ operating range is -10°F (-23°C) to 180°F (82°C).
- » Severe blow or shock to the Lift Magnet
- » Exposure to electrical current
- » Exposure to vibration

cam release is the mechanical device that breaks the Lift Magnet free from the load. Improper placement of the cam release on the load to be lifted can make releasing the load difficult.

"On/Off" magnet models feature an internal mechanism to control the Lift Magnet's magnetism. These magnets will be functionally on or off when the handle is in the corresponding locked "On" or "Off" position. See the **Handle Operation Instructions** section for more model specific information.

4. Proceed to move the load observing applicable standards for handling any suspended load. See the **Safety Measures** for general safe lifting protocols.
5. Set the load on the floor or an appropriate support and ensure that the load is perfectly settled before releasing the Lift Magnet from the load.
6. See the **Handle Operation Instructions** section more model specific information on how to release the Lift Magnet from the load.

than 5 degrees from horizontal. Magnet peel-off may occur and the load may fall.

- DO NOT** hoist a load before ensuring perfect magnetic contact. First make a TEST lift of 2 or 3 inches (5-7.5 cm) to ensure proper magnetic holding force.
- DO NOT** disengage the Lift Magnet before firmly setting down the load on the floor or appropriate support and making sure the load is secure.
- DO NOT** weld in close proximity to the Lift Magnet or use the Lift Magnet as a part of the ground circuit during a welding operation.
- DO NOT** place the magnet directly onto a grounded floor. Use a non-conductive spacer.
- DO NOT** lift people or loads with people on them
- DO NOT** leave suspended loads unattended.
- DO NOT** operate a Lift Magnet that is missing parts, damaged or malfunctioning.
- DO NOT** remove or obscure product labeling.
- DO NOT** lift loads higher than necessary or over people.
- DO NOT** center the Lift Magnet by pounding on the sides of the Lift Magnet with a hammer or other blunt instrument.



SAFETY PRECAUTIONS

Even though a magnet works through non-magnetic bodies such as dirt and non-ferrous materials in general the best efficiency of any Lift Magnet is achieved when the poles (the areas or surfaces of the Lift Magnet which make contact with the load) make complete contact with the load. It is therefore recommended to:

1. Never stand under load being lifted or lift over any people. Always use extra caution. Only use on thick material that does not flex or bend.
2. Clear any foreign material from the load and magnet poles before placing the Lift Magnet on the load. Avoid placing the Lift Magnet on steel that has irregular surface conditions.
3. Occasionally check the surface condition of the magnetic poles to make sure they are flat and not damaged or corroded during its time in use.
4. Keep the surface of the Lift Magnet and materials clean and free of chips, oil, slag, welding-beads, dirt, etc. This can be done by wiping the surface of the Lift Magnet off frequently with a wire brush, or shop rag.
5. Thin or large sheets that sag may cause the sheet to peel off the face of the Lift Magnet. (See **Maximum Working Load Limit** and Sheet Length chart)
6. After a period of time the pole faces may become somewhat rounded, reducing the Lift Magnet's effectiveness. Poles can be resurfaced up to 0.010" to 0.015" maximum.

LIFTING ANGLE AND EFFECTS OF UNBALANCED LOADS

Maximum Working Load Limit is achieved when the direction of force is perpendicular (90°) to the metal surface. Sudden or excessive shear, slide, friction, and peeling forces associated with movement or impact will cause a Lift Magnet to fail prematurely when a conveyed load is not balanced or tipped at an angle.

Perform a magnet/load balance test lift by raising the load off the ground by 2"-3" only. Reposition the Lift Magnet until the load is level.

Never lift a load at an angle in excess of 5 degrees from horizontal MATERIAL SURFACE



Lifting ferrous items using a magnet requires a good look at the length, width and thickness of the item. Thin metals do not absorb as many of the magnetic flux lines (magnetic energy) as thicker metals. Thin metals also flex, causing the steel to peel-off the Lift Magnet. Equally important is the physical size, flatness, surface conditions and type of steel. The charts below illustrate how surface finish and Carbon content effect the **Working Load Limit**.

PERCENTAGE OF STATED LIFTING POWER BY MATERIAL		PERCENTAGE OF STATED LIFTING POWER BY SURFACE FINISH		
CARBON CONTENT	LOW CARBON 0.05 - 0.29%	100%	GROUND SURFACE	100%
	MODERATE CARBON 0.30 - 0.59%	85%	ROUGH MACHINED	100%
	HIGH CARBON 0.60 - 0.99%	75%	FOUNDRY FINISH	85%
	HIGHER CARBON = HIGHER RESIDUAL*		ROUGH CAST	65%

* HIGH CARBON STEEL (TOOL STEEL) WILL ABSORB MAGNETISM & MAY MAGNETICALLY STICK TO STEEL SURFACE, SUCH AS THE LIFT MAGNET OR ATTRACT FERROUS PARTICLES.

MAXIMUM WORKING LOAD LIMIT (WLL) IN LBS (KG) & SHEET LENGTH (FEET) FOR MATERIAL THICKNESS**

MODEL NO.	3/16" (6' LN)	1/4" (6' LN)	3/8" (8' LN)	1/2" (8' LN)	1+" (10' LN)
BL0400	375 (170)	400 (181)	400 (181)	400 (181)	400 lbs
BL1000	725 (328)	800 (362)	875 (396)	975 (442)	1000 lbs
BL1500	875 (396)	1000 (453)	1400 (635)	1400 (635)	1500 lbs

**NOTE: These values are based on "Ideal Conditions" and are selected due to the sag characteristics of the specified sheet. It is recommended to use 2 or more lifts on a spreader bar when lifting sheets over 8 feet to prevent sheet flexing, sagging or peel-off. Thin material is susceptible to magnetic bleed through, resulting in two sheets being lifted at once. The item to be lifted must cover the entire length and width of the magnetic poles to properly engage and release.

HANDLE INSTALLATION AND OPERATION INSTRUCTIONS

HANDLE/CAM RELEASE INSTALLATION INSTRUCTIONS:

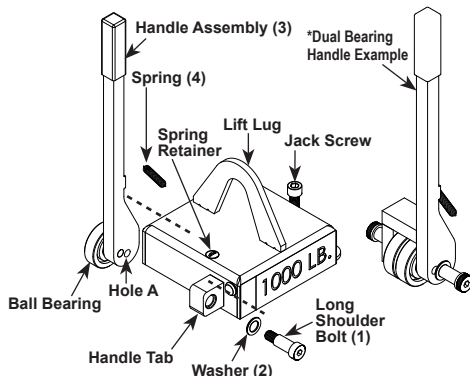

Set the Lift Magnet with the Jack Screw end DOWN, on a non-magnetic surface with the Handle Tab end UP in a vertical position.

NOTE: Shoulder bolts must be installed correctly to prevent bolt failures. Bushing holes and threaded areas must be free of dirt and contaminants before assembling the fasteners. The shoulder bolt must be installed with a tightening torque of 1150 in-lbs (96 ft-lbs). If no torque wrench is available, it is recommended to use a permanent thread locker to insure the shoulder bolt does not come loose. The tightness of the shoulder bolts should be checked on a regular preventative maintenance schedule.

Insert the Long Shoulder Bolt (1) into the Washer (2) then through the Handle Tab. Thread the Bolt into Hole "A" on the Handle Assembly (3). *Note: Place Washers between the handle Tabs and the Dual Bearing prior to inserting the shoulder bolt on each side. Attach the Spring (4) to the Spring Retainer welded onto the housing. Pull the handle towards the housing and attach the other end of the Spring to the Spring Retainer welded onto the Handle

Lay the Lift Magnet face down on a non-magnetic surface. Pull the handle down and release it to test proper functionality. The handle should return into an upright position. If the handle doesn't return to the upright position, check for proper installation.

HANDLE/CAM OPERATION INSTRUCTIONS:

Pull and hold the handle/cam release in the downward/horizontal release position while lowering the Lift Magnet onto the load. This will help prevent sudden attraction of the Lift Magnet to the steel and allow for more precise positioning of the Lift Magnet. When the Lift Magnet is in the desired position, slowly raise the handle/cam release into the vertical position to engage the Lift Magnet to the steel. Release the load by moving the lift free from the load. Use of the Jack Screw or a pry bar under the front flange may be necessary to release the Lift Magnet if the cam release device was accidentally positioned off the edge of the load. The Jack Screw is a backup release device.

ANNUAL BREAKAWAY CERTIFICATION TESTING

An annual Breakaway test, performed by an approved testing facility, is recommended to ensure that your Lift Magnet is performing to its optimal level. Under an "Ideal Condition" environment, a series of Breakaway tests will determine the current "de-rated" **Working Load Limit** of your magnet. This **Working Load Limit** must meet or exceed the value stated on your Lift Magnet. If the stated **Working Load Limit** is met, the Lift Magnet can be returned to use and scheduled for another Breakaway test in one year. The outcome of the test allows the operator/owner of the Lift Magnet to know that the Lift Magnet meets the lift standards as designed by the manufacturer.

If the stated **Working Load Limit** is not met, the Lift Magnet can possibly be machined to bring all magnet face poles back to a smooth, level condition. If that does not bring the Lift Magnet back to the manufacture's original **Working Load Limit**, the Lift Magnet should be removed from operation and replaced with another magnet.

A BREAKAWAY TEST CERTIFICATE, given at the conclusion of the testing, gives the operator/owner documentation of the Lift Magnet's performance.

Shipping Instructions For magnet calibration

Note: Customer is responsible for shipping to and from Industrial Magnetics, Inc., and any authorized repairs to the Lift Magnet. Please contact our customer service department at (888) 582-0822 to obtain your Customer Supplied Material (CSM) number. At this time, you will be required to supply a P.O.# for the test procedure described under "Calibration". Current fees for this procedure can be obtained by contacting the number listed above. Include your contact information and shipping address with your Lift Magnet and send to:

Industrial Magnetics, Inc.

1385 S M 75, Boyne City, MI 49712

CSM# _____, Attn: Quality Assurance, Calibration

COMMENTS, CONCERNS OR WARRANTY INFORMATION

We believe Industrial Magnetics, Inc. offers the finest line of Lift Magnets available today. Great pride has gone into the design and manufacture of this unit. Any comments, concerns or warranty questions should be directed to our Customer Service Department at 1-888-582-0822. We appreciate the opportunity to serve you!